

## Top Mounted Aluminum Channel System (DTA85-GLS) (Block System)

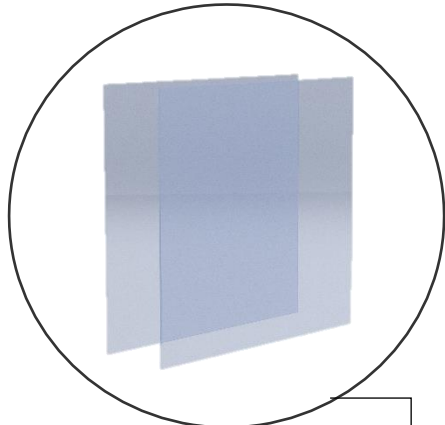

Packer

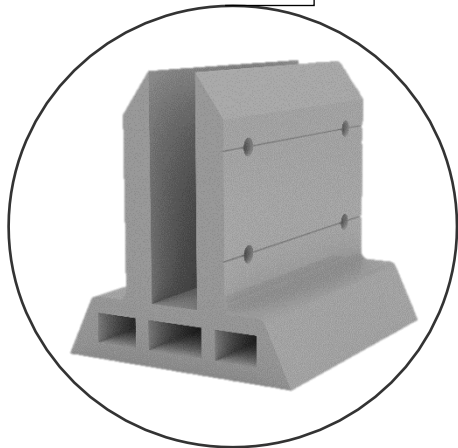
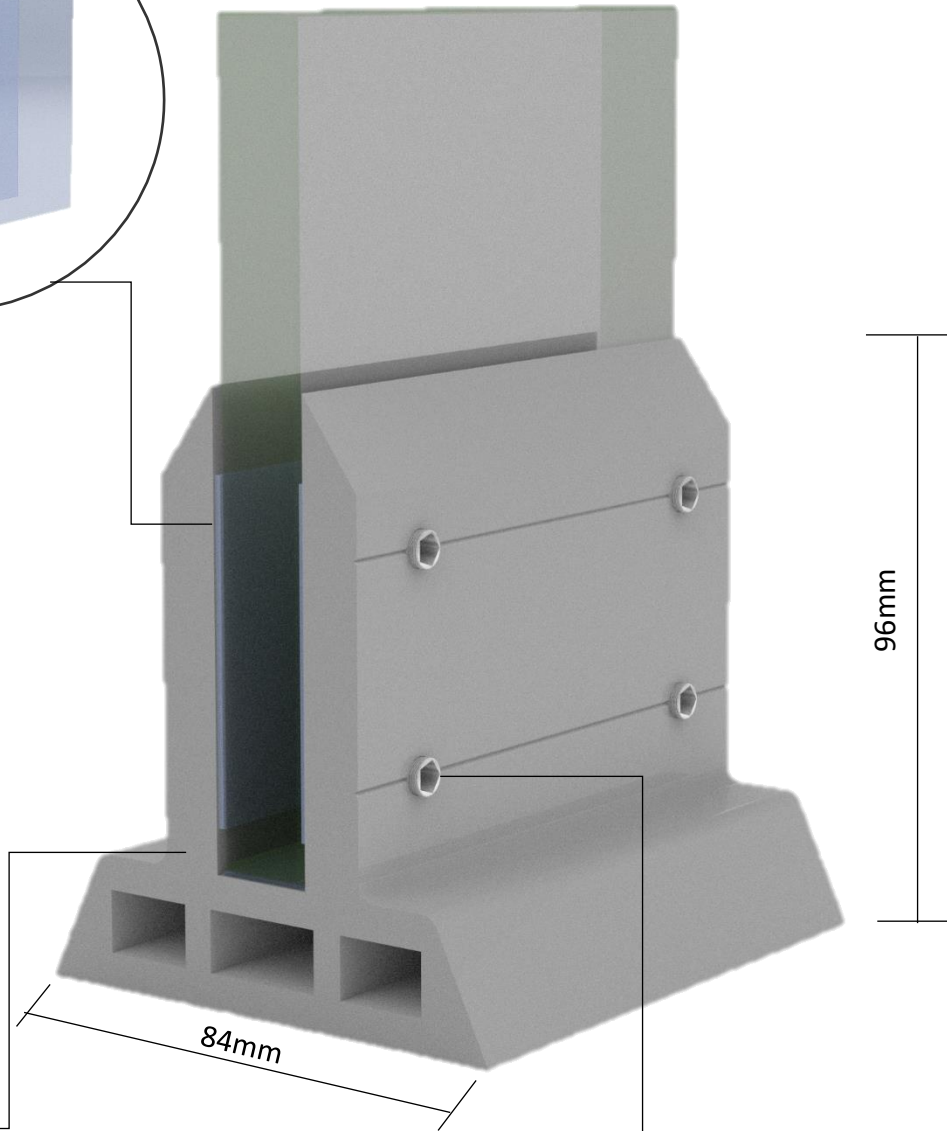

Block



M10X100 HRD CR  
GI HILTI Anchor Bolt



Grub Screw

## Specification



### **Block:**

- Material: AL6063 T6
- Length: 75mm
- Height: 96mm
- Width: 84mm
- Approx Weight: 0.490KG



### **Gasket:**

- Plactic Packers



### **Anchor Fastner:**

- Type: Hilti HRD C M10X100/120/140/160 (Counter Sunk) (As per client's requirement)



### **Powder Coating:**

- Type: AkzoNobel
- Color/Shade: As per client preference and subject to availability and feasibility
- Coat thickness: 80-100 Microns
- Coating warranty: 10 years of warranty

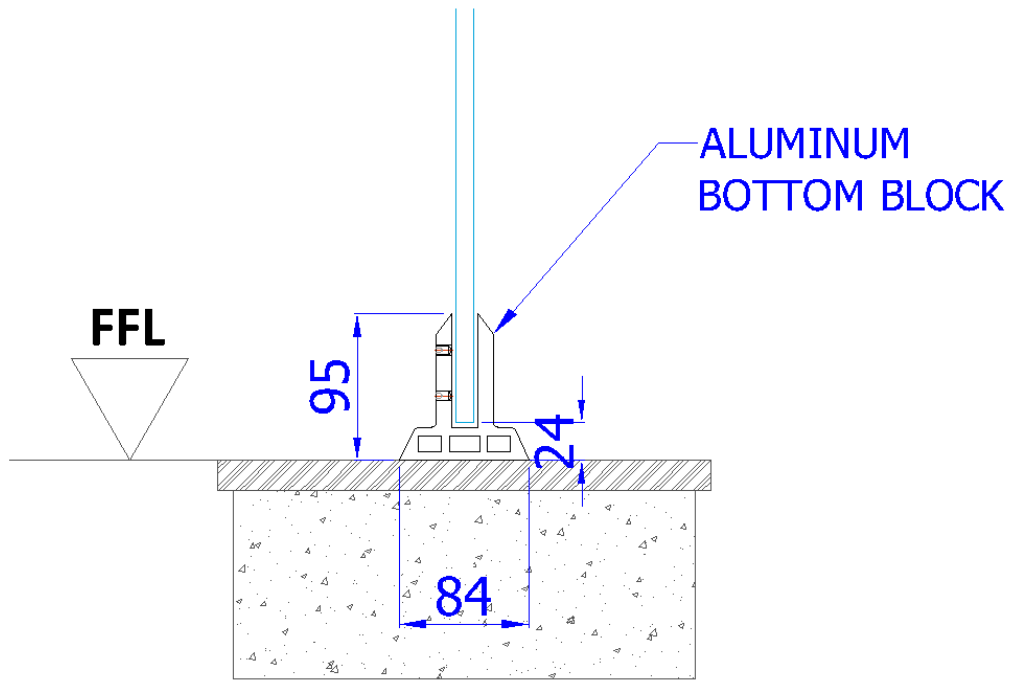

**SIDE VIEW**